

Exhaust System Installation for the Shelby GT500 PN- 100408



These instructions have been written to help you with the installation of your Borla Performance Exhaust System. Please read this document completely before beginning the installation of your system.

Please compare the parts in the box with the bill of materials provided to assure that you have all the parts necessary for this installation.

To ensure this part number fits your specific model year, please visit our website for the latest model year listings at www.BORLA.com.

Thank you for purchasing a Borla Performance Exhaust System.

Borla Performance Exhaust System (PN 100408) is designed for the Shelby GT500 with 428 cubic inch V-8 engine and manual transmission.

Borla Performance Industries recommends that an exhaust shop or professional after market parts installer perform the installation of this system. However, if you decide to perform the installation on your own it is recommended that two people are used. This installation should not be performed by one person due to the risk of injury. Ensure the installers use all under car safety precautions including eye protection.

Please take time to read and understand the following...

By installing your Borla Performance Exhaust System, you indicate that you have read this document and you agree with the terms stated below.

It is the responsibility of the purchaser to follow all installation instruction guidelines and safety procedures supplied with your Borla Performance Exhaust System

Borla Performance Industries assumes no responsibility for damages occurring from misuse, abuse, improper installation, improper operation, lack of responsible care, or all previously stated reasons resulting from incompatibility with other manufacturer's products and/or systems.

Included with your Borla Performance Exhaust System is a warranty card. Please read it carefully before you begin any work on your vehicle. If you should have any questions regarding our warranty policy, installation, or any other matter pertaining to your new Borla Performance Exhaust System, please give us a call at the number provided on the warranty card.

Minimum Required Tool List:

TOOLS:

- 1 3/8" Drive Ratchet
- 2 3/8" Drive Extension 3"
- 3 8mm, 15mm Deep Well Socket
- 4 Pry Bar
- 5 Flat blade screwdriver

SHOP SUPPLIES:

- 1 Spray Lubricant

Borla Performance - Bill of Materials

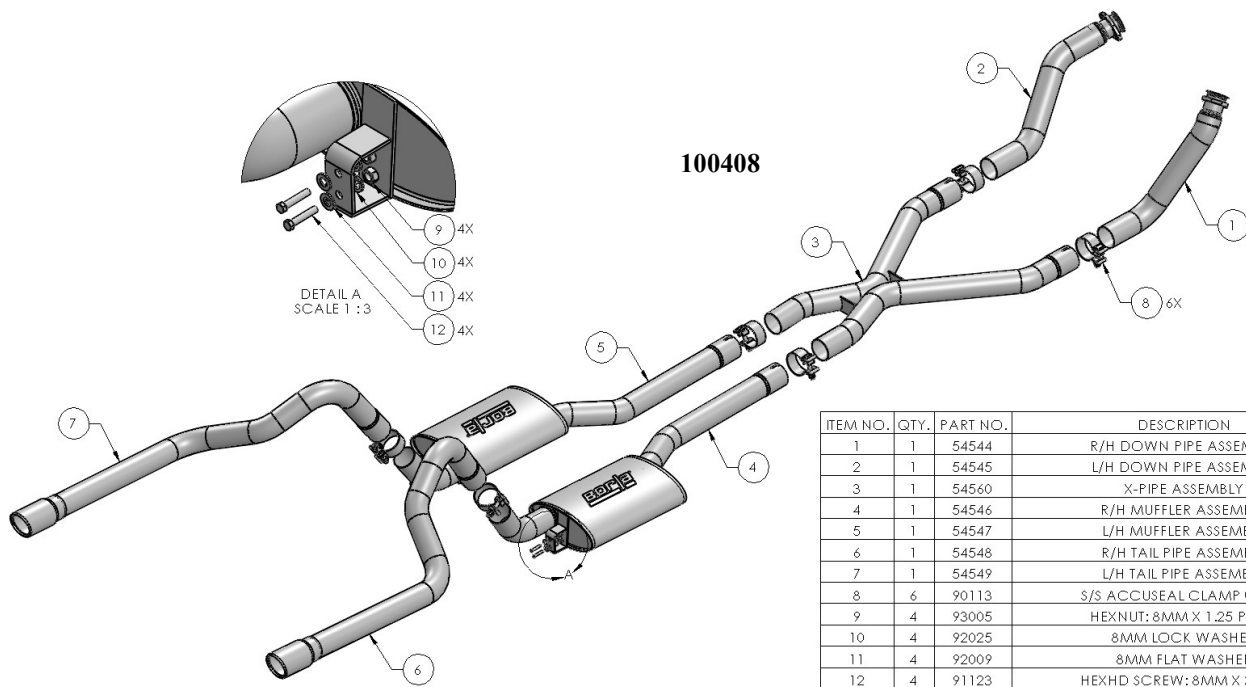

ITEM NO.	QTY.	PART NO.	DESCRIPTION
1	1	54544	R/H DOWN PIPE ASSEMBLY
2	1	54545	L/H DOWN PIPE ASSEMBLY
3	1	54560	X-PIPE ASSEMBLY
4	1	54546	R/H MUFFLER ASSEMBLY
5	1	54547	L/H MUFFLER ASSEMBLY
6	1	54548	R/H TAIL PIPE ASSEMBLY
7	1	54549	L/H TAIL PIPE ASSEMBLY
8	6	90113	S/S ACCUSEAL CLAMP Ø2.50
9	4	93005	HEXNUT: 8MM X 1.25 PITCH
10	4	92025	8MM LOCK WASHER
11	4	92009	8MM FLAT WASHER
12	4	91123	HEXHD SCREW: 8MM X 30MM