



Thank you for purchasing a Borla Performance Rear Section Exhaust System.

Precision manufactured using aircraft quality T-304 stainless steel; this system is designed to endure years of heavy use. Installing a Borla Performance Rear Section Exhaust System on your vehicle will eliminate the restrictive design of the stock exhaust, allowing your engine to discharge exhaust gas easier. The result is more horsepower and torque, longer engine life, and a distinctive throaty growl- all this, with easy bolt-on installation. These installation instructions have been written to help you in the installation of your Borla Performance Rear Section Exhaust System. Please read it completely before installing your system.

This Borla Performance Rear Section Exhaust System (Part number 11740) has been designed for the 2002 Nissan Sentra SER equipped with a 2.5L 4-cylinder engine and a manual transmission.

Borla Performance Industries recommends that an exhaust shop or professional after market parts installer, who has all the necessary equipment, tools and experienced personnel needed for proper installation, should perform the installation of this system. However, if you decide to perform the installation, we recommend someone should help you. Ensure the installer uses all under car safety precautions including eye protection.

Please take time to read and understand the following...

By installing your Borla Performance Rear Section Exhaust System, you indicate that you have read this document and you agree with the terms stated below.

It is the responsibility of the purchaser to follow all installation instruction guidelines and safety procedures supplied with your Borla Performance Rear Section Exhaust System
Borla Performance Industries assumes no responsibility for damages occurring from misuse, abuse, improper installation, improper operation, lack of responsible care, or all previously stated reasons resulting from incompatibility with other manufacturer's products and/or systems.

Included with your Borla Performance Rear Section Exhaust System is a warranty card. Please read it carefully before you begin any work on your vehicle. If you should have any questions regarding our warranty policy, installation, or any other matter pertaining to your new Borla Performance Rear Section Exhaust System, please give us a call at the number provided on the warranty card.

Borla Performance Rear Section Exhaust System Bill of Materials

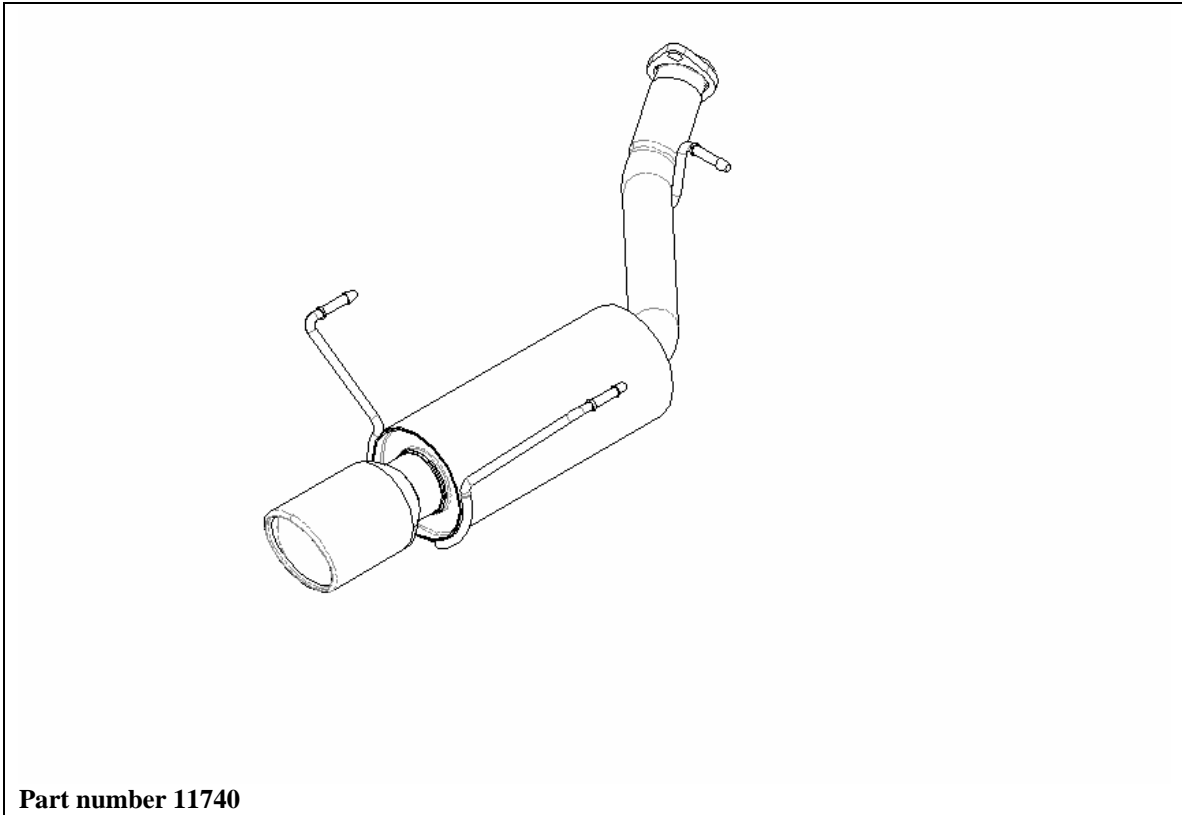

1. Rear section assembly

Caution!!! *Never* work on a hot exhaust system. Serious injury in the form of burns can result If the vehicle has been in use and the exhaust system is hot, allow vehicle to cool for at least 1 hour. Always wear eye protection when working under any vehicle.

Note: It is our recommendation that you use a hoist or hydraulic lift to facilitate the installation of your new Borla Performance Rear Section Exhaust System.

Taking all under car safety precautions, lift the vehicle using a hoist or hydraulic lift. Once this has been done, you may begin the removal of your old exhaust system from your vehicle.

Note: Before removing the original exhaust system from your vehicle, please compare the parts you have received with the bill of materials provided on the previous page to assure that you have all the parts necessary for the installation of your new Borla Performance Rear Section Exhaust System.

Original Exhaust System Removal

Note: With a used vehicle, we suggest a penetrating spray lubricant to be applied liberally to all exhaust fasteners and allowing a significant period of time for the chemical to lubricate the threads before attempting to disassemble.

1. Unbolt flange just in front of the muffler assembly making sure to remove ground strap.
2. Lubricate all hangers and rubber brackets.
3. Using a muffler stand or an additional person to hold the muffler assembly up in place, remove all hangers from the rubber brackets on the vehicle. There are three total, two just above the muffler assembly at the rear and one just above the flange in front.
4. Finally, remove the muffler assembly shown in figure 2 from your vehicle.

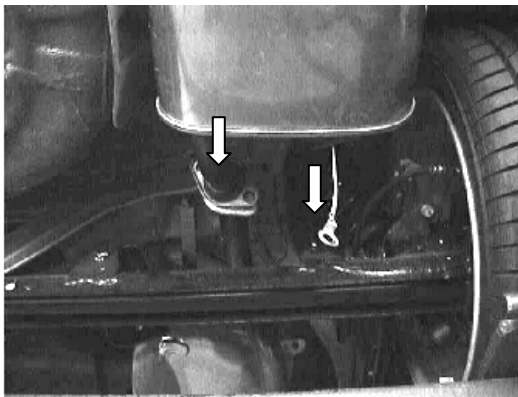

Figure 1



Figure 2

Borla Performance Rear Section Exhaust System Installation

Warning: Use extreme caution during installation. Torque all fasteners according to manufacturer's torque values and tightening sequence. **DO NOT** use air impact tools to tighten fasteners on Borla Performance Exhaust Systems. Use of such tools may result in bent flanges or gasket contact areas leading to exhaust leaks. If any welding is performed, protect vehicle brake, fuel, vacuum or similar lines. Always check for any damage after welding has been done. Also check inside vehicle for damage to such items as carpet, inner liner, etc. Always have a class C fire extinguisher and a bucket of water available during any welding process.

1. Place the Borla Performance Rear Section Exhaust System shown in figure 3 into position installing the hangers into the rubber brackets.
2. Using the original hardware, bolt flange shown in figure 4 together making sure to install ground strap.



Figure 3



Figure 4

Note: When you first start your vehicle after the installation of your new Borla Performance Rear Section Exhaust System, there may be some smoke and fumes coming from the system. This is a protective oil based coating used in the manufacturing of mandrel bent performance exhaust tubing. This is not a problem and will disappear within a very short period of time after the exhaust has reached normal operating temperatures.



Congratulations!!! You have completed the installation of the world famous Borla Performance Stainless Steel Exhaust System.