

2006 Chevy Silverado 2500/3500 & GMC Sierra 2500/3500 Diesel Exhaust System Installation



Precision manufactured using aircraft quality T-304 stainless steel; this system is designed to endure years of heavy use. Installing a Borla Performance Exhaust System on your vehicle will eliminate the restrictive design of the stock exhaust, allowing your engine to discharge exhaust gas easier. The result is more horsepower and torque, longer engine life, and a distinctive throaty growl- all this, with easy bolt-on installation. These installation instructions have been written to help you in the installation of your Borla Performance Exhaust System. Please read it completely before installing your system.

Thank you for purchasing a Borla Performance Cat-Back™ Exhaust System.

These Borla Performance Cat-Back™ Exhaust Systems have been designed for 2006 Chevy Silverado 2500/3500 and 2006 GMC Sierra 2500/3500 each equipped with 6.6L Diesel V8 engine, 2 or 4-wheel drive and automatic or manual transmissions. 140180 is designed for Crew Cab Long Bed; 140181 is designed for Crew Cab Short Bed; 140182 is designed for Extended Cab Long Bed; 140183 is designed for Extended Cab Short Bed.

Borla Performance Industries recommends that an exhaust shop or professional after market parts installer, who has all the necessary equipment, tools and experienced personnel needed for proper installation, should perform the installation of this system. However, if you decide to perform the installation, we recommend someone should help you. Ensure the installer uses all under car safety precautions including eye protection.

Please take time to read and understand the following...

By installing your Borla Performance Exhaust System, you indicate that you have read this document and you agree with the terms stated below.

It is the responsibility of the purchaser to follow all installation instruction guidelines and safety procedures supplied with your Borla Performance Exhaust System

Borla Performance Industries assumes no responsibility for damages occurring from misuse, abuse, improper installation, improper operation, lack of responsible care, or all previously stated reasons resulting from incompatibility with other manufacturer's products and/or systems.

Included with your Borla Performance Exhaust System is a warranty card. Please read it carefully before you begin any work on your vehicle. If you should have any questions regarding our warranty policy, installation, or any other matter pertaining to your new Borla Performance Exhaust System, please give us a call at the number provided on the warranty card.

Minimum Required Tool List:**TOOLS:**

1. 3/8" Drive Ratchet
2. 3/8" Drive Extension 3"
3. 15mm Socket
4. Pry Bar
5. Flat Blade Screwdriver

SHOP SUPPLIES:

1. Spray Lubricant

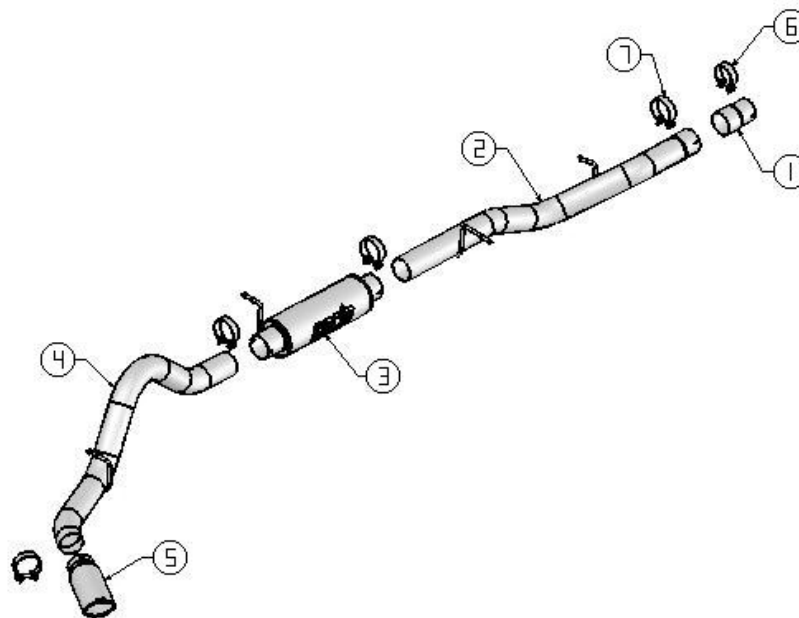
Borla Performance # 140180 Crew Cab Long Bed Cat-Back™ Bill of Materials

1. Adapter pipe
2. Intermediate pipe assembly
3. Muffler assembly
4. Tail pipe
5. Tip
6. 3.50" clamp
7. 4.00" clamp (qty 4)

Minimum Required Tool List:**TOOLS:**

1. 3/8" Drive Ratchet
2. 3/8" Drive Extension 3"
3. 15mm Socket
4. Pry Bar
5. Flat Blade Screwdriver

SHOP SUPPLIES:

1. Spray Lubricant

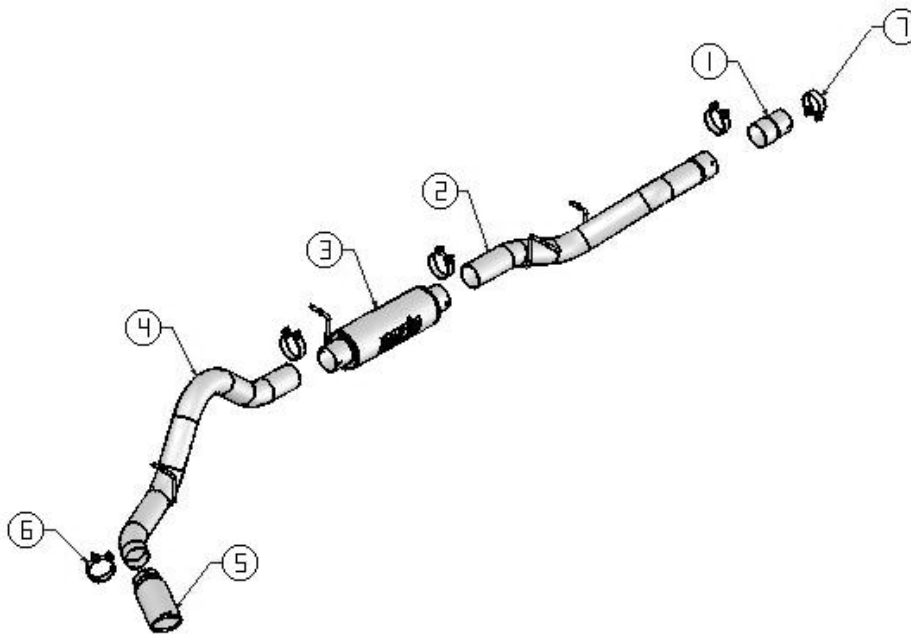
Borla Performance # 140181 Crew Cab Short Bed Cat-Back™ Bill of Materials

1. Adapter pipe
2. Intermediate pipe assembly
3. Muffler assembly
4. Tail pipe
5. Tip
6. 3.50" clamp
7. 4.00" clamp (qty 4)

Minimum Required Tool List:**TOOLS:**

1. 3/8" Drive Ratchet
2. 3/8" Drive Extension 3"
3. 15mm Socket
4. Pry Bar
5. Flat Blade Screwdriver

SHOP SUPPLIES:

1. Spray Lubricant

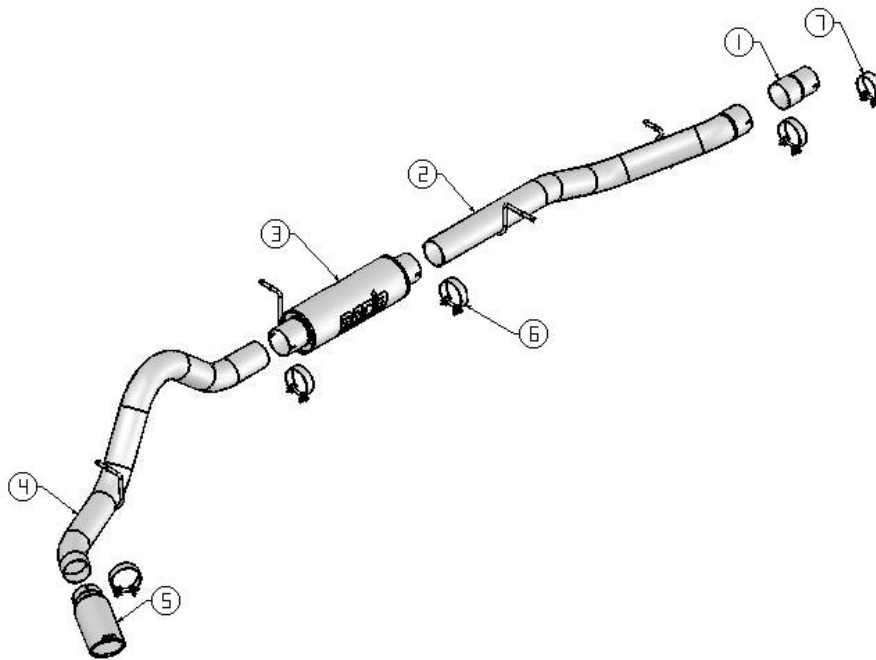
Borla Performance # 140182 Extended Cab Long Bed Cat-Back™ Bill of Materials

1. Adapter pipe
2. Intermediate pipe assembly
3. Muffler assembly
4. Tail pipe
5. Tip
6. 4.00" clamp (qty 4)
7. 3.50" clamp

Minimum Required Tool List:**TOOLS:**

1. 3/8" Drive Ratchet
2. 3/8" Drive Extension 3"
3. 15mm Socket
4. Pry Bar
5. Flat Blade Screwdriver

SHOP SUPPLIES:

1. Spray Lubricant

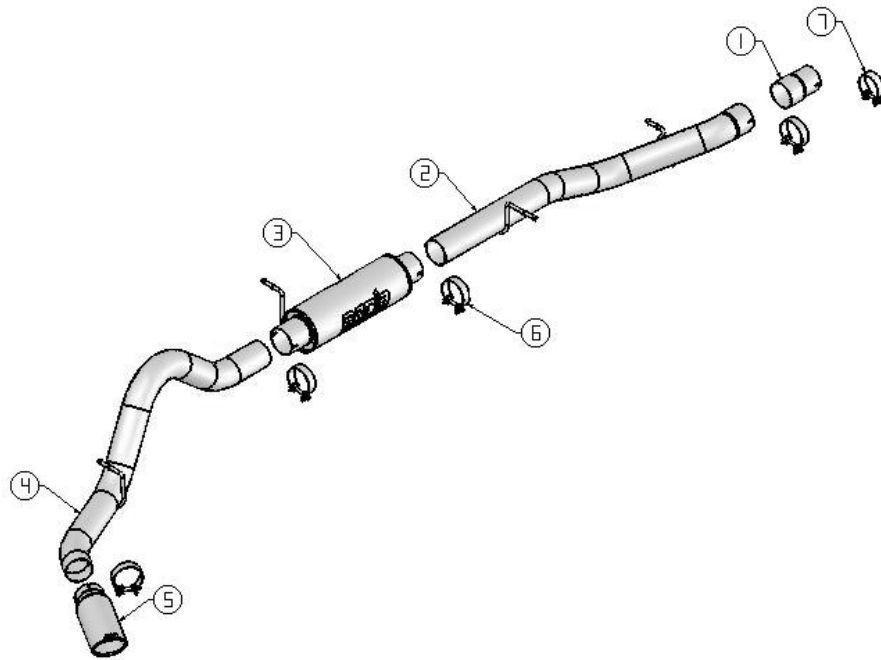
Borla Performance # 140183 Extended Cab Short Bed Cat-Back™ Bill of Materials

1. Adapter pipe
2. Intermediate pipe assembly
3. Muffler assembly
4. Tail pipe
5. Tip
6. 3.50" clamp
7. 4.00" clamp (qty 4)

Caution!!! *Never work on a hot exhaust system. Serious injury in the form of burns can result* If the vehicle has been in use and the exhaust system is hot, allow vehicle to cool for at least 1 hour. Always wear eye protection when working under any vehicle.

Note: It is our recommendation that you use a hoist or hydraulic lift to facilitate the installation of your new Borla Performance Cat-Back™ Exhaust System.

Taking all under car safety precautions, lift the vehicle using a hoist or hydraulic lift. Once this has been done, you may begin the removal of your old exhaust system from your vehicle.

Note: Before removing the original exhaust system from your vehicle, please compare the parts you have received with the bill of materials provided on the previous page to assure that you have all the parts necessary for the installation of your new Borla Performance Cat-Back™ Exhaust System.

Original Exhaust System Removal

Note: With a used vehicle, we suggest a penetrating spray lubricant to be applied liberally to all exhaust fasteners and allowing a significant period of time for the chemical to lubricate the threads before attempting to disassemble.

1. Unbolt the clamp shown in figure 1 located behind the catalytic converter.
2. Lubricate all hangers and rubber isolators.
3. Using a muffler stand or an additional person to hold the exhaust up into position, remove the hangers from the rubber isolators and remove exhaust from the vehicle as shown in figure 2.

Warning: Use extreme caution during installation. Torque all fasteners according to manufacturer's torque values and tightening sequence. **DO NOT** use air impact tools to tighten fasteners on Borla Performance Exhaust Systems. Use of such tools may result in bent flanges or gasket contact areas leading to exhaust leaks.

Borla Performance Cat-Back™ Exhaust System Installation

1. Place the 3.50" clamp over the inlet of the adapter pipe and set it into position as shown in figure 3. **Do Not** tighten the clamp.



Figure 1



Figure 2

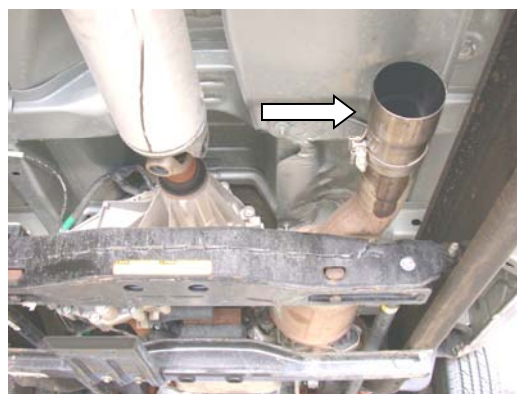

Figure 3

Warning: Use extreme caution during installation. Torque all fasteners according to manufacturer's torque values and tightening sequence. **DO NOT** use air impact tools to tighten fasteners on Borla Performance Exhaust Systems. Use of such tools may result in bent flanges or gasket contact areas leading to exhaust leaks.

Borla Performance Cat-Back™ Exhaust System Installation (continued)

2. Place a clamp over the expanded end of the intermediate pipe assembly and set it into position over the adapter pipe as shown in figure 4 making sure to install the hanger into the rubber isolator. Do Not tighten the clamp.
3. Place a clamp over the expanded end of the muffler assembly and set it into position as shown in figure 5. Do Not tighten the clamp.
4. Place a clamp over the expanded end of the tail pipe and set it into position as shown in figure 6 making sure to install the hanger into the rubber isolator. Do Not tighten the clamp.
5. Place a clamp over the expanded end of tip and set it into position as shown in figure 7. Do Not tighten the clamp.
6. Check your exhaust system for proper clearance under the vehicle and also for tip alignment.
7. Once position has been determined to be correct, tighten the Accuseal clamps to 32-35 ft. lbs.
6. Before starting your vehicle, make sure to check all wires, hoses, brake lines, body parts and tires for safe clearance from the exhaust system.
7. Start vehicle and check for any leaks. If any leaks are found, determine cause (such as loose or incorrectly positioned clamp) and repair as necessary.

Note: When you first start your vehicle after the installation of your new Borla Performance Exhaust System, there may be some smoke and fumes coming from the system. This is a protective oil based coating used in the manufacturing of mandrel bent performance exhaust tubing. This is not a problem and will disappear within a very short period of time after the exhaust has reached normal operating temperatures.



Figure 4



Figure 5



Figure 6



Figure 7