

Shelby GT500 System Installation



These instructions have been written to help you with the installation of your Borla Performance Exhaust System. Please read this document completely before beginning the installation of your system.

Please compare the parts in the box with the bill of materials provided to assure that you have all the parts necessary for this installation.

To ensure this part number fits your specific model year, please visit our website for the latest model year listings at www.BORLA.com.

Thank you for purchasing a Borla Performance Cat-Back™ Exhaust System.

Borla Performance Cat-Back™ Exhaust Systems (Part number 140499, 140500, 140501) are designed for the Shelby GT500 equipped with a 5.8L Supercharged V8 engine and manual transmissions.

Borla Performance Industries recommends that an exhaust shop or professional after market parts installer perform the installation of this system. However, if you decide to perform the installation on your own it is recommended that two people are used. This installation should not be performed by one person due to the risk of injury. Ensure the installers use all under car safety precautions including eye protection.

Please take time to read and understand the following...

By installing your Borla Performance Exhaust System, you indicate that you have read this document and you agree with the terms stated below.

It is the responsibility of the purchaser to follow all installation instruction guidelines and safety procedures supplied with your Borla Performance Exhaust System

Borla Performance Industries assumes no responsibility for damages occurring from misuse, abuse, improper installation, improper operation, lack of responsible care, or all previously stated reasons resulting from incompatibility with other manufacturer's products and/or systems.

Included with your Borla Performance Exhaust System is a warranty card. Please read it carefully before you begin any work on your vehicle. If you should have any questions regarding our warranty policy, installation, or any other matter pertaining to your

Minimum Required Tool List:

TOOLS:

- 1 3/8" Drive Ratchet
- 2 3/8" Drive Extension 3"
- 3 10, 15mm Sockets
- 4 Pry Bar
- 5 Flat blade screwdriver

SHOP SUPPLIES:

- 1 Spray Lubricant

Borla Performance Cat-Back™ Bill of Materials

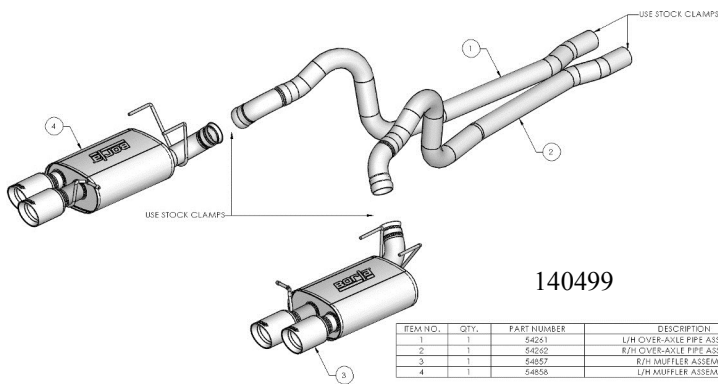

140499

ITEM NO.	QTY.	PART NUMBER	DESCRIPTION
1	1	54261	L/H OVER-AXLE PIPE ASSEMBLY
2	1	54262	R/H OVER-AXLE PIPE ASSEMBLY
3	1	54857	R/H MUFFLER ASSEMBLY
4	1	54858	L/H MUFFLER ASSEMBLY

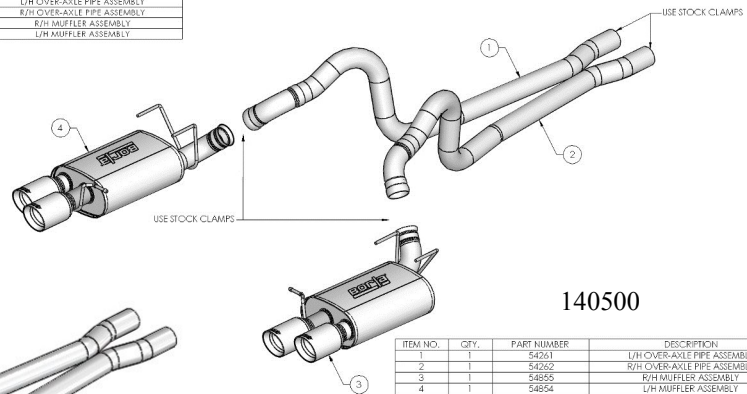

140500

ITEM NO.	QTY.	PART NUMBER	DESCRIPTION
1	1	54261	L/H OVER-AXLE PIPE ASSEMBLY
2	1	54262	R/H OVER-AXLE PIPE ASSEMBLY
3	1	54855	R/H MUFFLER ASSEMBLY
4	1	54854	L/H MUFFLER ASSEMBLY

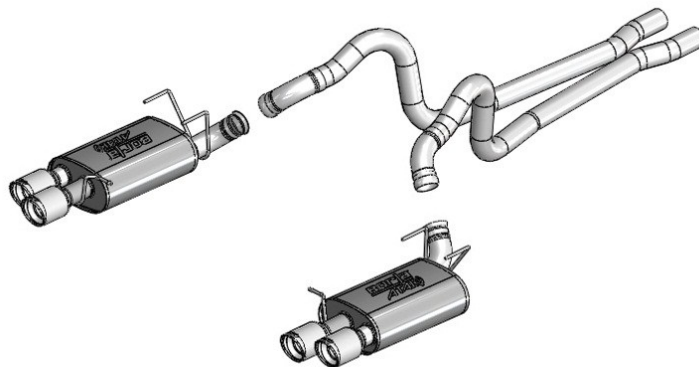

140501

ITEM NO.	QTY.	PART NUMBER	DESCRIPTION
1	1	54261	L/H OVER-AXLE PIPE ASSEMBLY
2	1	54262	R/H OVER-AXLE PIPE ASSEMBLY
3	1	54859	R/H MUFFLER ASSEMBLY
4	1	54860	L/H MUFFLER ASSEMBLY

Caution!!! *Never work on a hot exhaust system. Serious injury in the form of burns can result* If the vehicle has been in use and the exhaust system is hot, allow vehicle to cool for at least 1 hour. Always wear eye protection when working under any vehicle.

Note: It is our recommendation that you use a hoist or hydraulic lift to facilitate the installation of your new Borla Performance Cat-Back™ Exhaust System.

Taking all under car safety precautions, lift the vehicle using a hoist or hydraulic lift. Once this has been done, you may begin the removal of your old exhaust system from your vehicle.

Note: Before removing the original exhaust system from your vehicle, please compare the parts you have received with the bill of materials provided on the previous page to assure that you have all the parts necessary for the installation of your new Borla Performance Cat-Back™ Exhaust System.

Original Exhaust System Removal

Note: With a used vehicle, we suggest a penetrating spray lubricant to be applied liberally to all exhaust fasteners and allowing a significant period of time for the chemical to lubricate the threads before attempting to disassemble.

1. Lubricate hangers and rubber isolators.
2. Loosen the clamps located just behind the x-pipe. (See Fig. 1)
3. Loosen the clamps located just in front of each muffler assembly. (See Fig. 2)
4. Beginning with the left (driver) side, using a flat blade screwdriver, pull the clip to disengage it from the front pipe.
5. Remove the left (driver) side over-axle pipe by removing the front of the pipe first then sliding it out of the muffler assembly.
6. Repeat steps 3 thru 5 for the removal of the right side over-axle pipe.
7. Loosen and remove the factory hanger bolts and remove left-side muffler assembly. Carefully remove hangar assembly rubber isolators from hangars and keep for re-installation of your new exhaust system. (See Fig. 3)
8. Remove the rear pipe clamps for re-use in the installation of your new exhaust system. (See Fig. 4)
9. Repeat steps 7 thru 9 for the removal of the right (passenger) side muffler assembly.

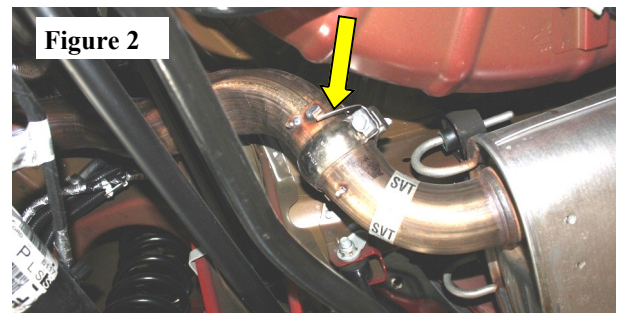
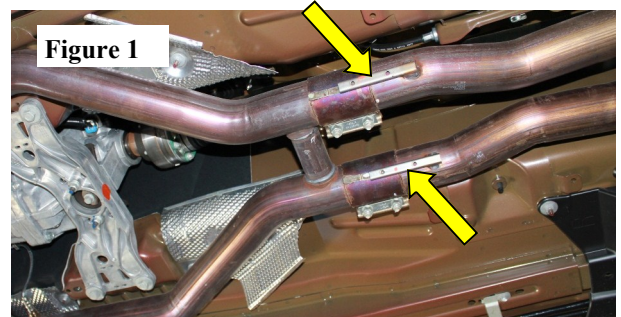

Warning: Use extreme caution during installation. Torque all fasteners according to manufacturer's torque values and tightening sequence. **DO NOT** use air impact tools to tighten fasteners on Borla Performance Exhaust Systems. Use of such tools may result in bent flanges or gasket contact areas leading to exhaust leaks.

Borla Performance Cat-Back™ Exhaust System Installation

1. Orient and install factory left-side and right-side hanger assemblies (from step 7 of page 3) to muffler hangers of each rear muffler. Place a clamp over the expanded end of the left (driver) side muffler assembly and set it up into position installing the hangers into the rubber isolators. (See Fig. 5)
2. Repeat step 2 for the installation of the right (passenger) side muffler assembly.
3. Place the original clamp over the expanded end of left (driver) side over-axle pipe and set it into position as shown by first installing the rear portion into the muffler assembly. (See Fig. 6)
4. Repeat step 3 for the installation of the right (passenger) side over-axle pipe.
5. Check your exhaust system for proper clearance under the vehicle and also for tip alignment. (See Figs. 7 & 8)
6. Once position has been determined to be correct, tighten the Accuseal™ clamps to 32-35 ft. lbs.
7. Before starting your vehicle, make sure to check all wires, hoses, brake lines, body parts and tires for safe clearance from the exhaust system.
8. Start vehicle and check for any leaks. If any leaks are found, determine cause (such as loose or incorrectly positioned clamp) and repair as necessary.

Congratulations!!! You have completed the installation of the world famous Borla Performance Stainless Steel Exhaust System.

Note: When you first start your vehicle after the installation of your new Borla Performance Exhaust System, there may be some smoke and fumes coming from the system. This is a protective oil based coating used in the manufacturing of mandrel bent performance exhaust tubing. This is not a problem and will disappear within a very short period of time after the exhaust has reached normal operating temperatures.

