

Installation for Porsche Carrera 911 (993) PN-140729



******* Please compare the parts in the box with the bill of materials provided *****
to assure that you have all the parts necessary for this installation.**

These instructions have been written to help you with the installation of your Borla Performance Exhaust System. Please read this document completely before beginning the installation of your system.

To ensure this part number fits your specific model year, please visit our website for the latest model year listings at www.BORLA.com

Thank you for purchasing a Borla Performance Cat-Back™ Exhaust System.

Borla Performance Cat-Back™ Exhaust System (PN-140729) is designed for the Porsche Carrera 911 (993) equipped with a 3.6L V6 engine, manual transmission.

Borla Performance Industries recommends that an exhaust shop or professional after market parts installer, who has all the necessary equipment, tools and experienced personnel needed for proper installation, should perform the installation of this system. However, if you decide to perform the installation, we recommend someone should help you. Ensure the installer uses all under car safety precautions including eye protection.

Please take time to read and understand the following...

By installing your Borla Performance Exhaust System, you indicate that you have read this document and you agree with the terms stated below.

It is the responsibility of the purchaser to follow all installation instruction guidelines and safety procedures supplied with your Borla Performance Exhaust System.

Borla Performance Industries assumes no responsibility for damages occurring from misuse, abuse, improper installation, improper operation, lack of responsible care, or all previously stated reasons resulting from incompatibility with other manufacturer's products and/or systems.

Included with your Borla Performance Exhaust System is a warranty card. Please read it carefully before you begin any work on your vehicle. If you should have any questions regarding our warranty policy, installation, or any other matter pertaining to your new Borla Performance Exhaust System, please give us a call at the number provided on the warranty card.

Minimum Required Tool List:

TOOLS:

1. 3/8” Drive Ratchet
2. 3/8” Drive Extension 3”
3. 15mm Deep Well Socket
4. 10mm Socket
- 5.
6. Pry Bar

SHOP SUPPLIES:

- 1 Spray Lubricant

Borla Performance - Bill of Materials

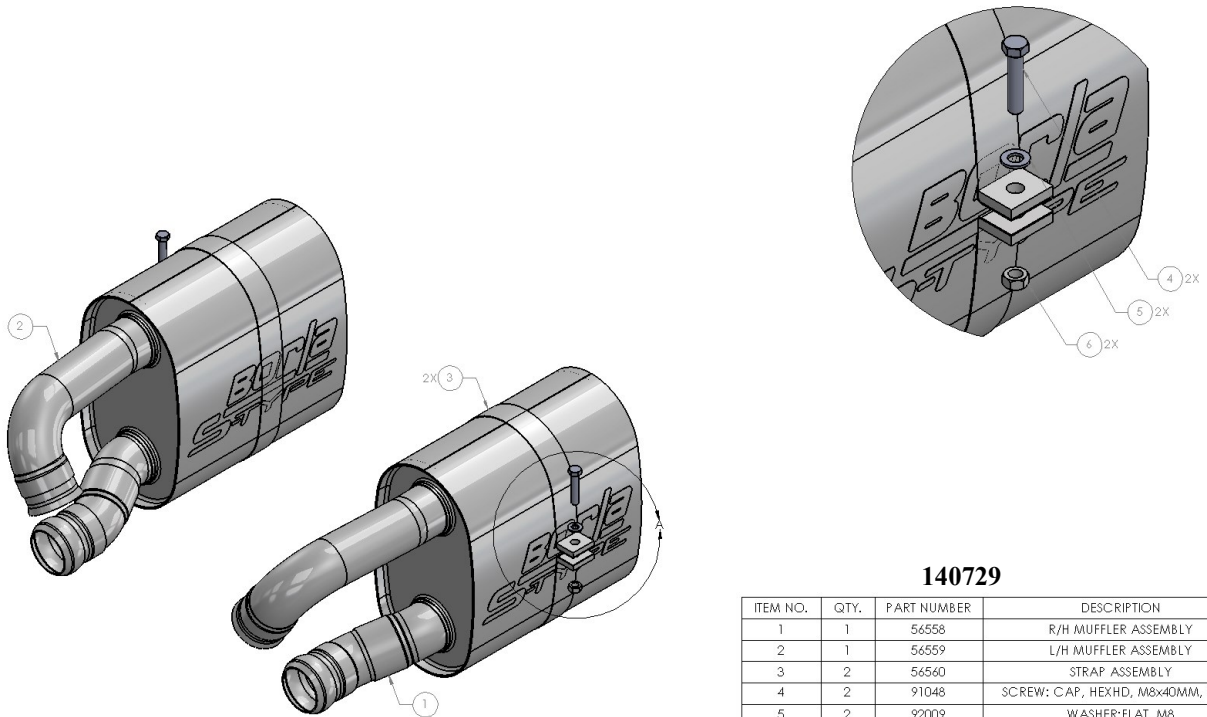

140729

ITEM NO.	QTY.	PART NUMBER	DESCRIPTION
1	1	56558	R/H MUFFLER ASSEMBLY
2	1	56559	L/H MUFFLER ASSEMBLY
3	2	56560	STRAP ASSEMBLY
4	2	91048	SCREW: CAP, HEXHD, M8x10MM, 1.25p
5	2	92009	WASHER: FLAT, M8
6	2	93005	NUT: HXHD, M8 X 1.25 PITCH

Caution!!! *Never work on a hot exhaust system. Serious injury in the form of burns can result if the vehicle has been in use and the exhaust system is hot, allow vehicle to cool for at least 1 hour. Always wear eye protection when working under any vehicle.*

Note: *It is our recommendation that you use a hoist or hydraulic lift to facilitate the installation of your new Borla Performance Exhaust System.*

Taking all under car safety precautions, lift the vehicle using a hoist or hydraulic lift. Once this has been done, you may begin the removal of your old exhaust system from your vehicle.

Note: *Before removing the original exhaust system from your vehicle, please compare the parts you have received with the bill of materials provided on the previous page to assure that you have all the parts necessary for the installation of your new Borla Performance Exhaust System.*

Note: *With a used vehicle, we suggest a penetrating spray lubricant to be applied liberally to all exhaust fasteners and allowing a significant period of time for the chemical to lubricate the threads before attempting to disassemble.*

Original Exhaust System Removal

1. Lubricate all hangers, rubber isolators, bolts and nuts.
2. Loosen and remove L/H and R/H side tips assemblies put to side for re-installation. (See Fig. 1)
3. Carefully loosen and remove original clamps on both sides kipping original hardware for re-installation. (See Fig. 2)
4. Remove the R/H and L/H original straps from muffler assembly. (See Fig. 3)
5. Start on left side remove the muffler assembly, using a muffler stand or an additional person to hold the muffler up into position and remove from the vehicle. (See Fig. 4)
6. Repeat the same process on the right side.
7. Exhaust system removed. (See Fig. 5)

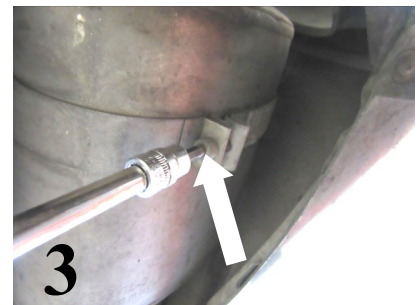
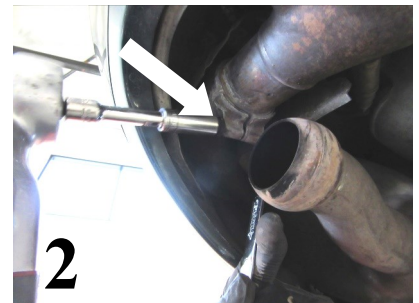
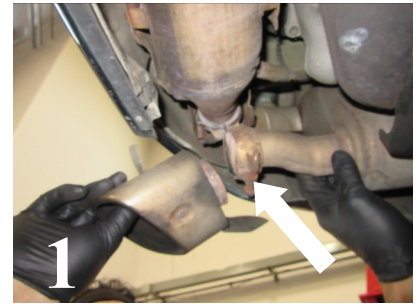

Borla Performance Cat-Back™ Exhaust System Installation

1. Orient components on floor referencing page-2 drawing. (See Fig. 6)
2. Place the **R/H Muffler Assembly** up into position, mounting straps will be assembled on the vehicle. (See Fig. 7) Do Not tighten strap.
3. Repeat the same process on the **L/H Muffler Assembly**. Do Not tighten strap.
4. Secure the muffler inlet flare on R/H and L/H side using the original clamp. (See Fig. 8)
5. Using the hardware that is provided for the **Strap Assembly** tighten the bolt and nut. (See Fig. 9)
6. Place the original clamp on R/H and L/H side tail pipes assemblies. (See Fig. 10)
7. Check your exhaust system for proper clearance under the vehicle and also for tip alignment. Starting at front flanges and moving to rear of vehicle, tighten flange hardware bolts. Orient position of bolt (on supplied clamps) between (not over) pipe notches and tighten to 35 ft. lbs. torque. (See Fig. 11)
8. Align tips and tighten hardware. Loosen clamps to rotate or slide pipe for better alignment.
9. Before starting your vehicle, make sure to check all wires, hoses, brake lines, body parts and tires for safe clearance from the exhaust system.
10. Start vehicle and check for any leaks. If any leaks are found, determine cause (such as loose or incorrectly positioned clamp) and repair as necessary.

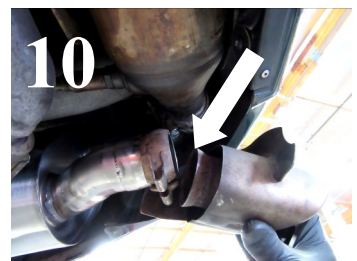
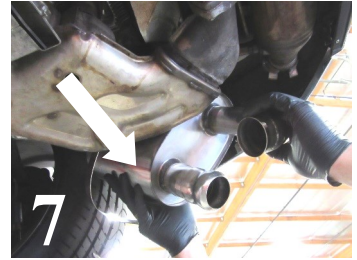

WARNING: Use extreme caution during installation. Torque all fasteners according to manufacturer's torque values and tightening sequence. **DO NOT** use air impact tools to tighten fasteners on Borla Performance Exhaust Systems. Use of such tools may result in bent flanges or gasket contact areas leading to exhaust leaks.

NOTE: When you first start your vehicle after the installation of your new Borla Performance Exhaust System, there may be some smoke and fumes coming from the system. This is a protective oil based coating used in the manufacturing of mandrel bent performance exhaust tubing. This is not a problem and will disappear within a very short period of time after the exhaust has reached normal operating temperatures.