

Installation Guide for Can-Am Maverick X3

PNs: 12677, 12677CB, 12678, 12678CB, 60733CB, 60733SB



******* Please compare the parts in the box with the bill of materials provided *****
to assure that you have all the parts necessary for this installation.**

These instructions have been written to help you with the installation of your Borla Performance exhaust system. Please read this document completely before beginning the installation of your system.

To ensure this part number fits your specific model year, please visit our website for the latest model year listings at www.BORLA.com

Thank you for purchasing a Borla Performance Cat-Back™ exhaust system.

Borla Performance Cat-Back™ exhaust system PNs 12677, 12677CB, 12678, 12678CB are designed for the Can-Am Maverick X3, equipped with a 900cc inline-3 turbo-charged engine and 2+4WD automatic transmission.

Borla Performance Tip Kit PNs 60733CB and 60733SB are designed for the Can-Am Maverick X3 with either the stock exhaust system or Borla PNs 12677, 12677CB, 12678, and 12678CB.

Borla Performance Industries recommends that an exhaust shop or professional after market parts installer, who has all the necessary equipment, tools and experienced personnel needed for proper installation, should perform the installation of this system. However, if you decide to perform the installation, we recommend someone should help you. Ensure the installer uses all under car safety precautions including eye protection.

Please take time to read and understand the following...

By installing your Borla Performance exhaust system, you indicate that you have read this document and you agree with the terms stated below.

It is the responsibility of the purchaser to follow all installation instruction guidelines and safety procedures supplied with your Borla Performance exhaust system.

Borla Performance Industries assumes no responsibility for damages occurring from misuse, abuse, improper installation, improper operation, lack of responsible care, or all previously stated reasons resulting from incompatibility with other manufacturer's products and/or systems.

Included with your Borla Performance exhaust system is a warranty card. Please read it carefully before you begin any work on your vehicle. If you should have any questions regarding our warranty policy, installation, or any other matter pertaining to your new Borla Performance exhaust system, please give us a call at the number provided on the warranty card.

Minimum Required Tool List:

TOOLS:

1. 3/8" drive ratchet
2. 13mm socket
3. 13mm wrench
4. T-30 Torx
5. 10mm socket
6. Pick or wire and pliers

SHOP SUPPLIES:

1. Spray lubricant

Borla Performance - Bill of Materials

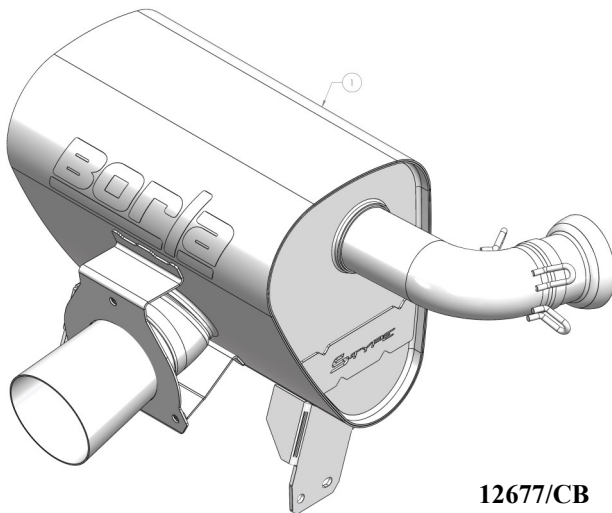

12677/CB

ITEM NO.	PART NUMBER	DESCRIPTION	QTY.
1	57710	MUFFLER ASSEMBLY	1

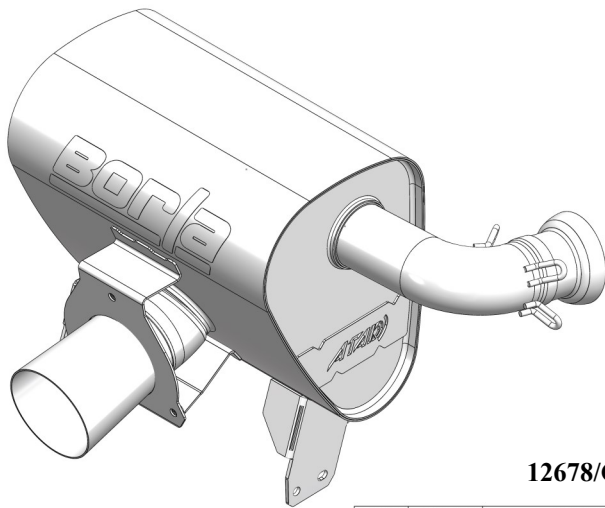

12678/CB

ITEM NO.	PART NUMBER	DESCRIPTION	QTY.
1	57737	MUFFLER ASSEMBLY	1

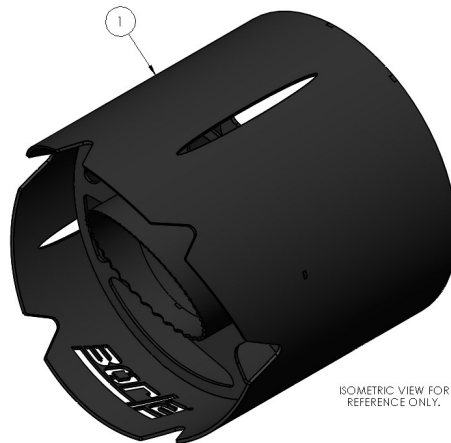

60733CB/SB

ISOMETRIC VIEW FOR REFERENCE ONLY.

ITEM NO.	PART NUMBER	DESCRIPTION	QTY.
1	480438CB	TIP: Ø6.00 X 6.28" LG.	1

TIP KIT WITH STAINLESS BRUSHED FINISH WILL BE 60733SB

Caution!!! *Never work on a hot exhaust system. Serious injury in the form of burns can result if the vehicle has been in use and the exhaust system is hot, allow vehicle to cool for at least 1 hour. Always wear eye protection when working under any vehicle.*

Note: It is our recommendation that you use a hoist or hydraulic lift to facilitate the installation of your new Borla Performance Exhaust System.

Taking all under car safety precautions, lift the vehicle using a hoist or hydraulic lift. Once this has been done, you may begin the removal of your old exhaust system from your vehicle.

Note: Before removing the original exhaust system from your vehicle, please compare the parts you have received with the bill of materials provided on the previous page to assure that you have all the parts necessary for the installation of your new Borla Performance Exhaust System.

Note: With a used vehicle, we suggest a penetrating spray lubricant to be applied liberally to all exhaust fasteners and allowing a significant period of time for the chemical to lubricate the threads before attempting to disassemble.

Original Exhaust System Removal

1. Loosen and remove (5) bolts securing the plastic cover to the rear of the vehicle and remove the cover (Fig. 1).
2. Loosen and remove the (4) bolts and nuts securing the muffler assembly to the vehicle (Figs. 2-3). The bolts are not captive so you will need to use a wrench to hold their matching nuts during removal. You will be reusing the original hardware on your new system. The longer of the bolts is used on the passenger side of the vehicle.
3. Using a pick or pliers and a metal cable, carefully remove the (4) springs around the inlet to the factory muffler (Fig. 4) . You will be reusing the original springs on your new system.
4. Rotate the original muffler assembly toward you and out of the vehicle (Fig. 5).
5. Remove the (3) bolts securing the tip and remove the spark arrestor to re-use on your new system (Fig. 6). You will be reusing this hardware on your new system.
6. Original exhaust system removed.

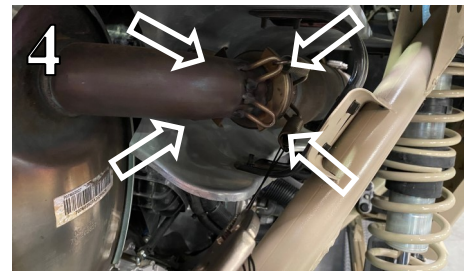
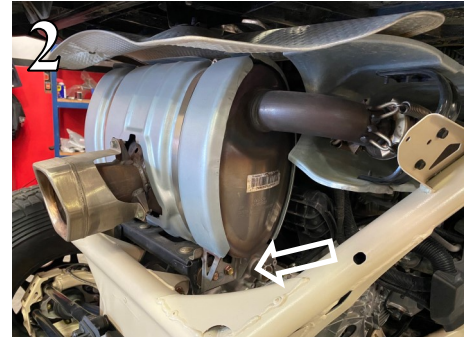

Borla Performance Cat-Back™ Exhaust System Installation

1. Orient components on shop floor according to Borla bill of materials drawing on page 2.
2. Rotate **Muffler Assembly** into position with the flange seating onto the vehicle and the brackets locating on the mounting location of the stock muffler (Fig. 7).
3. Reinstall original hardware to attach **Muffler Assembly** to the vehicle. The longer of the two bolts are used on the passenger side (Fig. 8).
4. Using a pick or pliers and a metal cable, reinstall original springs and make sure that the exhaust fully seats onto the vehicle (Fig. 9).
5. Install original spark arrestor by inserting it into the outlet of the exhaust (Fig. 10).
6. Install the original tip on the **Muffler Assembly** by reusing the original hardware (Fig. 11).
7. If you have purchased **60733CB/SB** you will install this the same way as described for installation of the original tip assembly (Fig. 12).
8. Reinstall plastic cover using the original hardware.
9. Before starting your vehicle, make sure to check all wires, hoses, brake lines, body parts and tires for safe clearance from the exhaust system.
10. Start the vehicle and check for any leaks. If any leaks are found, determine cause and repair as necessary.



WARNING: Use extreme caution during installation. Torque all fasteners according to manufacturer's torque values and tightening sequence. **DO NOT** use air impact tools to tighten fasteners on Borla Performance Exhaust Systems. Use of such tools may result in bent flanges or gasket contact areas leading to exhaust leaks.

NOTE: When you first start your vehicle after the installation of your new Borla Performance Exhaust System, there may be some smoke and fumes coming from the system. This is a protective oil based coating used in the manufacturing of mandrel bent performance exhaust tubing. This is not a problem and will disappear within a very short period of time after the exhaust has reached normal operating temperatures.